



CNS Range



# DESIGN, MANUFACTURING, REPAIR

OPTIMEX is exclusively dedicated to conception, manufacturing, tests and after sales services of Canned Motor Pumps. Created in 1998, our company has been growing ever since, and became a major actor in this field on the international market.

Used for dangerous, toxic and explosive liquids as well as for major and valuable processes, canned motor pumps are chosen for their robustness and reliability. They confer the highest safety level on the market thanks to its double hermetically sealed containment.

Among others, we design and manufacture our pumps according to the following standards:

- ISO 2858, ISO 15783, API 685, directive 2006/42/EC (Electrical machinery) directive 2014/34/EU (ATEX), EAC (Eurasian Conformity), CUTR (Customs Union Technical Regulations For Belarus, Kazakhstan and Russia), directive 97/23/EC - 2014/68/EU (PED).
- OPTIMEX answers the quality management requirements established by ISO 9001 and NF EN ISO/CEI 80079-34.



Remaining attentive to its international customers' requirements, OPTIMEX adapts its production to local Ex-proof directives (ATEX, CUTR, UL, CSA).

## SUMMARY

CNS RANGE DESIGNATION .....	3
CNS RANGE CHARACTERISTICS DIAGRAMS .....	4
SPECIFICATIONS OF DESIGN .....	6
MATERIALS .....	8
OPTIONS OF CONSTRUCTION .....	9
GENERAL ARRANGEMENT DRAWING .....	10
INSTRUMENTATIONS .....	11
SPARE PARTS .....	12

## + CNS RANGE

The CNS range is the normalized serie for the chemical industry. It meets safety, simplicity, reliability and cost efficiency.



### CANNED MOTOR PUMP ISO 15783:

for hazardous area in chemical application.

Construction according to  
ISO5199/ISO15783  
Dimensions according to ISO2858  
Compliance with European directive:

- Machine - 2006/42/EC
- Low voltage electrical equipment - 2014/35/EU
- ATEX - 2014/34/EU

### WORKING RANGE:

Flow ..... Up to 60 m<sup>3</sup>/h  
Head ..... Up to 60 m  
Frequency ..... 50Hz/60Hz  
Pumping temperature ..... -120°C / 140°C  
Pressure design ..... Up to 16 bar

### + CONDITIONS OF USE:

Canned motor pumps are used on application with very dangerous liquid as:

- Hydrochloric acid: HCl,
- Hydrofluoric acid: HF
- Hydrogen sulfide: H<sub>2</sub>S
- ...

This technology is used for its high level of security brought by its second containment.

### + CONSTRUCTION:

Standard horizontal centrifugal pump with a canned motor. There is not any dynamic seal on shaft.

### ADVANTAGES:

- Simple machine design with only 2 slides bearings in the liquid
- Compact dimensions given by a monobloc assembly.
- Unecessary lineage at the installation
- Good control of the liquid heating
- No oil lubrication
- High reliability: important MTBF

### DOCUMENTATION:

Documentation delivered with the pump is compliant with CE requirements.

- User manual
- Sectional drawing requirements with parts list
- Hydraulic curve
- Dimensional drawing
- Conformity certificate
- Test report

### CERTIFICATES:

- **Material certificates**  
On demand we can deliver certificate 2.2 according to EN 10204.
- **Hydrostatic certificate**  
Each pump is tested at 1.5 times the design pressure
- **Performance test certificate**  
Each pump is tested according to ISO 9906 grade 2. On demand, we can deliver a NPSH test.

### PAINTING:

RAL 5018 for motopump color  
RAL 9005 for baseplate color  
Painting procedure according to OPTIMEX standard PG B 01.

### PUMP DESIGNATION:

Each OPTIMEX pump is identified by a unique serial number (BFxxxx) and a complete designation name which reflects all main characteristics of the pump.

### CNSI-A 32/160 In\_P4F2Bd

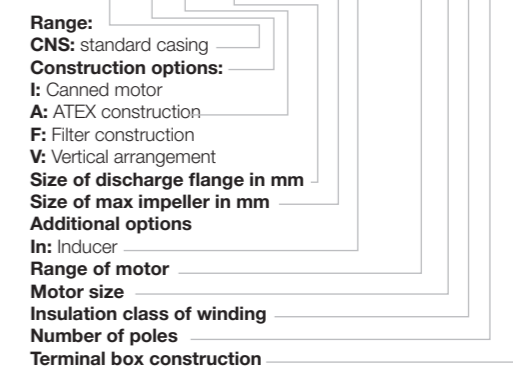

### CIRCULATION:

A part of the pumped liquid is used to lubricate the slides bearings. According to the process, different circulations can be proposed:

CATEGORY	LETTER	PUMPING TYPE
Overpressured	S	Clear liquid, boiling, hot or cold
Filtered	F	Loaded liquid, hot or cold

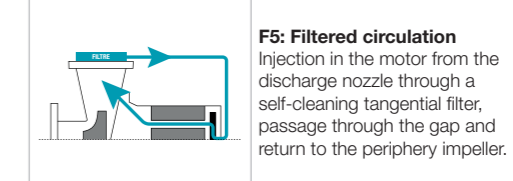
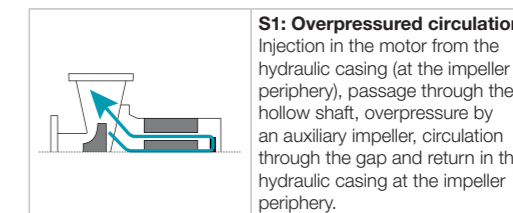

**+ CNS PERFORMANCE CURVES**

**CURVE RANGE 50HZ / 2900 RPM**

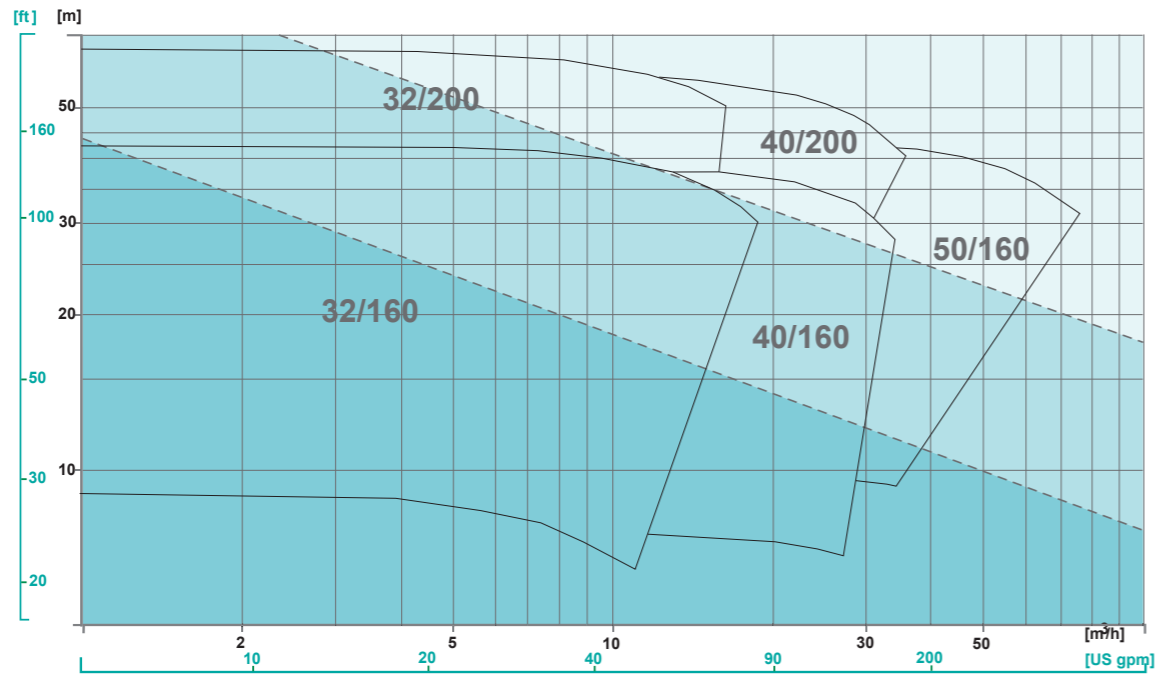

**CURVE RANGE 60HZ / 3500 RPM**

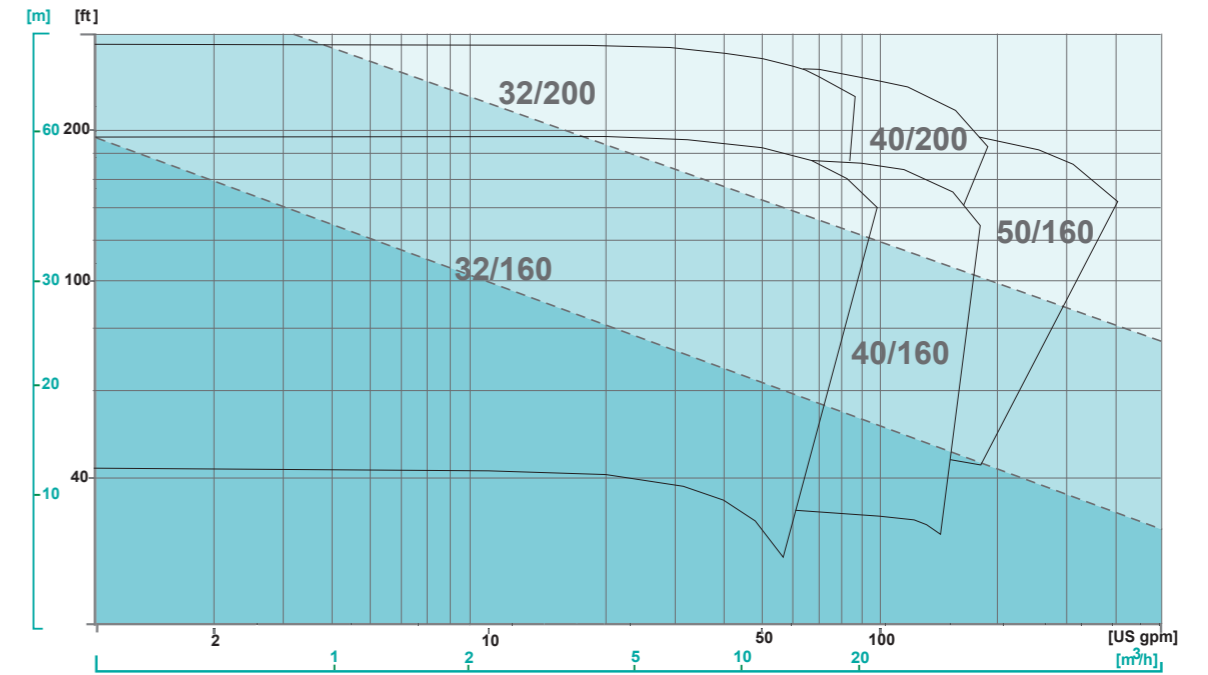

**CURVE RANGE 50HZ / 1450 RPM**

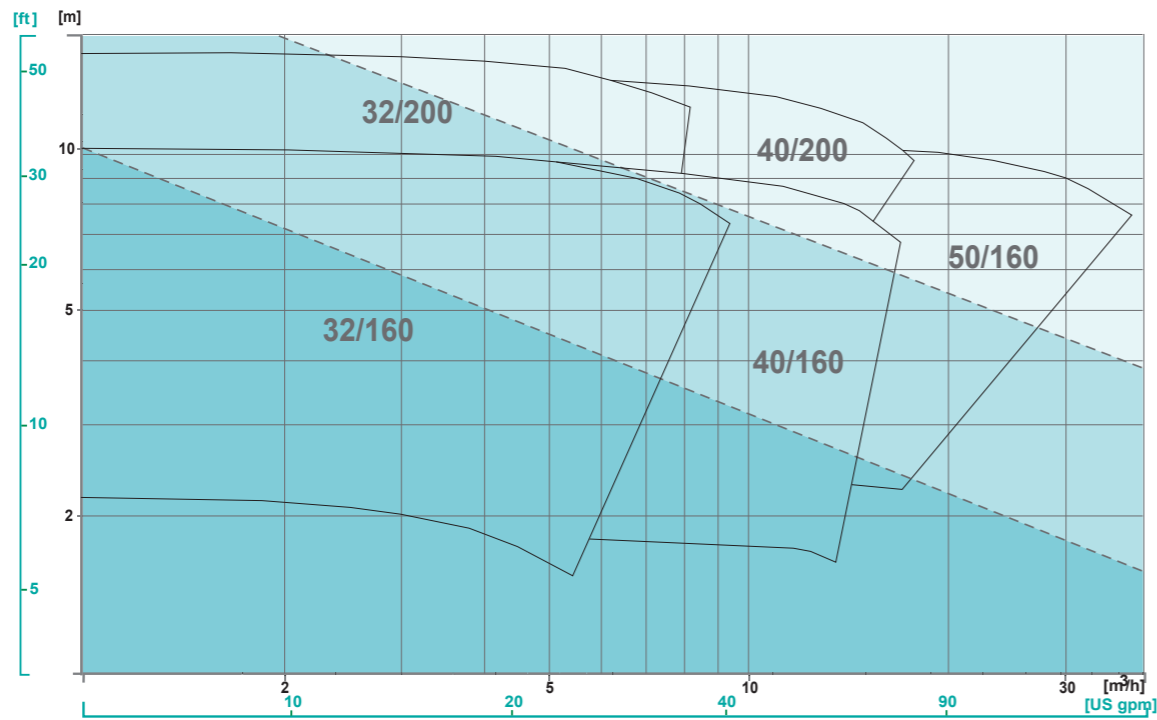

**CURVE RANGE 60HZ / 1750 RPM**

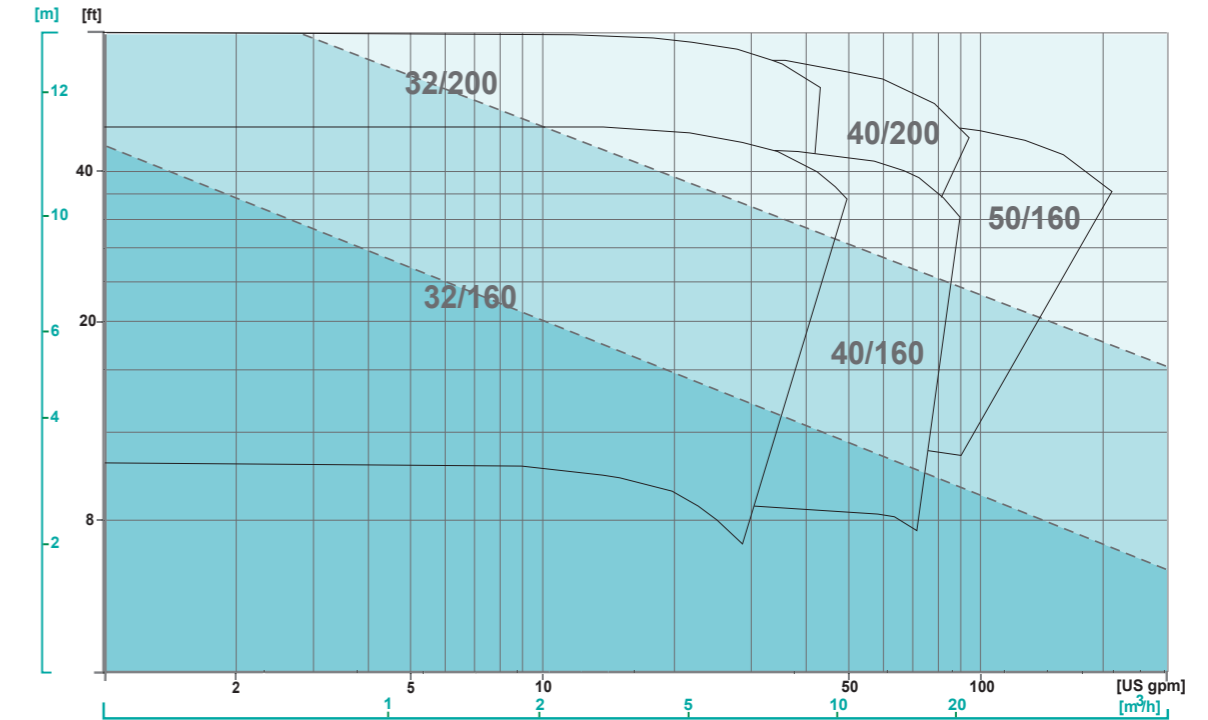

**MOTOR SIZE COMBINATION**  
(must be adjusted case by case)

- P4 (4kW)
- P7 (7kW)
- P10 (10kW)

**+ SPECIFICATIONS OF DESIGN**

**STANDARD CONSTRUCTION**

- 1 Standard flanges according to EN 1092-1, PN16 RF.
  - 2 Casing wear ring
  - 3 Casing drain nut
  - 4 Motor frame (secondary containment)
  - 5 Auxiliary impeller
- 
- A Secondary containment chamber
  - B Leak proof feedthrough
  - C Motor windings
  - D Rear bearing support

**CONSTRUCTION OPTIONS**

- Welded drain with flange and valve
- Flanges according to ASME B16.5 #150 RF
- SIC30 slide bearings
- Inducer: for low NPSH application
- Additional separate instrumentation junction box
- Levelling feet
- Tangential filter

Moving parts  
 Hermetically sealed casing

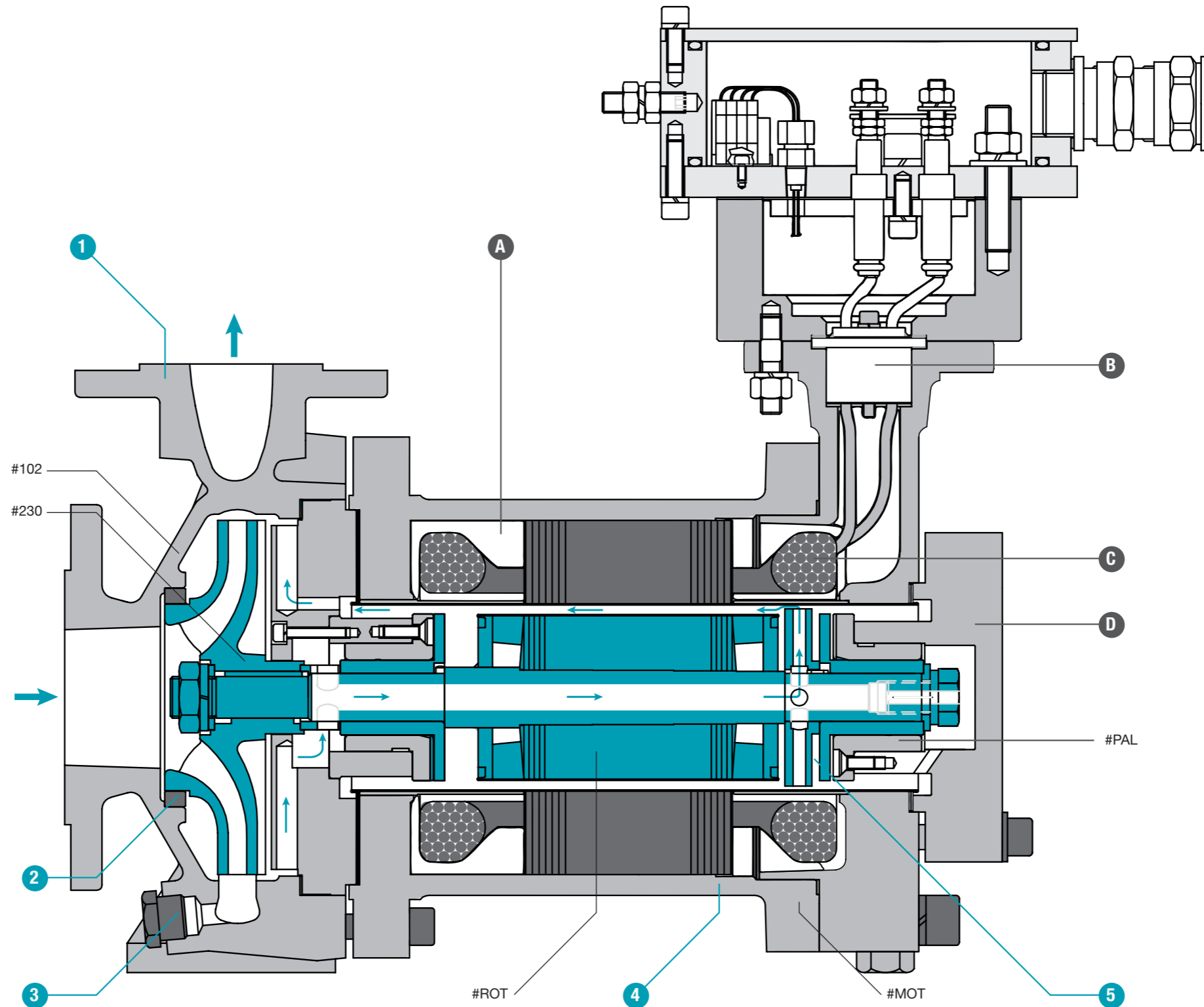

## + CONSTRUCTION

### + MATERIALS

#### FORCES AND MOMENTS

Flanges of pumps are designed to resist the forces and moments according to ISO 5199.

#### LIMIT OF PRESSURE AND TEMPERATURE:

Pumping temperature..... -120°C / 140°C  
 Pressure design..... Up to 16 bar

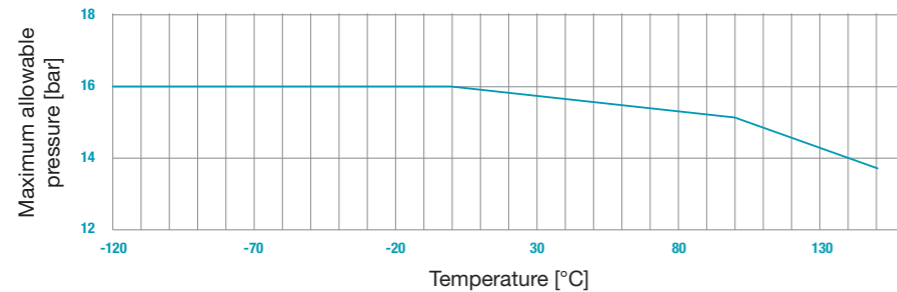

#### PARTS LIST

Rep	Designation	Material
#102	Casing	1.4409 (316L)
#230	Impeller	1.4409 (316L)
#400 #440	Parts under pressure	1.4404 (316L)
#ROT	Shaft Rotor liner	1.4404 (316L) 1.4404 (316L)
#MOT	Motor casing Stator liner	0.7043 (FGS400-18) 1.4404 (316L)
#PAL	Bearing	1.4404 / Graphite
-	Gaskets	PTFE or PTFE modified

### + DRIVER

#### DESCRIPTION

Due to its specific fire barrier between terminal box and motor frame, OPTIMEX motor is able to contain a leakage to the atmosphere during a long period.

Windings of motor are protected by PTC sensor in the order to avoid the overheating. The use of a motor with variable frequency drive (VFD) is possible as connecting PTC directly to VFD.

Three phases asynchronous motor  
 Starting mode: direct on all range of motors  
 Voltage: 50 Hz: 230V, 380V, 400V, 690V  
 60 Hz: 277V, 440V, 480V

Voltage tolerances: +/- 10%  
 Code: II 2G Ex de IIC T5/T4  
 Protection according to EN 60034: IP66  
 Isolation class H: for liquid up to 100°C  
 Terminal box: in "e" protection

#### EXPLOSION PROTECTION

OPTIMEX motor is compliant with ATEX directive 2014/34/EU

To operate in security these motopumps in explosive atmospheres, following protection measures are mandatory:

- Protection from an abnormal temperature rise  
 The temperature of the motor frame must stay below the temperature ranges are shown on the maker plate.
- Motopump filling  
 To keep the motopump full of liquid and thus outside the explosion zone, the user must ensure by any suitable method that it is always full.

### + OPTIONS OF CONSTRUCTION

#### MOTOR BEARINGS

Two types of motor bearings are available on the CNS range:

##### • Graphite construction:

Slide bearings are one of the major parts that confer such a good reliability to seal-less pumps. For single stage canned motor pumps, the mono-bloc shaft composed of all the rotating elements of the machine is supported with 2 slide bearings that are totally submersed in the pumped liquid. Once the pump's filling is guaranteed (and controlled with appropriate instrumentation) and pump is started, the mobile rotates free from any friction and wearing thanks to a thin film.

##### • SIC30 construction (optional):

For critical applications with a risk of dry running (frequent and delicate start-up or critical liquids for which full characteristics have been transmitted and approved by OPTIMEX), SIC30 bearings are advised and proposed. In case of bearing capacity losses, friction between sleeve in SIC30 and specific coating on shaft sleeve is acceptable for small periods.

#### INDUCER: FOR LOW NPSH APPLICATION

To reduce NSPH required of pump or to allow a certain quantity dissolved of gas in the process. An inducer can be added at the pump's suction.

#### ANTI-VIBRATION MOUNTS/ FREE STANDING CRUTCHES

#### TANGENTIAL FILTER

For dirty liquid and in order to protect the pump, it is possible to install a tangential filter at the discharge flange.

Limits acceptable:

Maximum quantity of particles: 0.1% in weight

Maximum size of particles: 1 mm

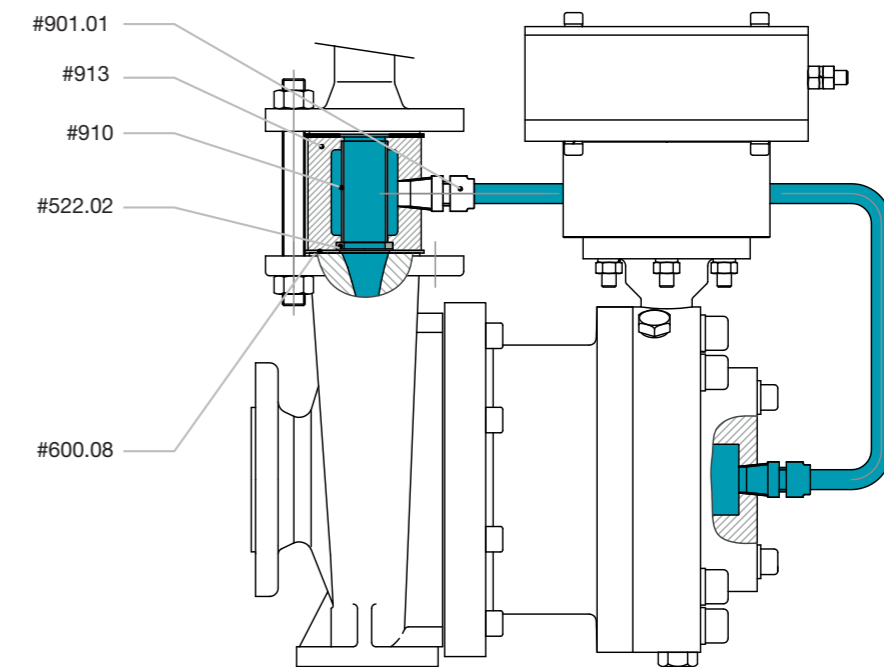

Rep	Designation	Material
#901.01	Swagelock fitting	1.4404 (316L)
#913	Spool piece	1.4404 (316L)
#910	Strainer filter	1.4404 (316L)
#522.02	Filter washer	1.4404 (316L)
#600.08	Gasket	graphite spirale wounded gasket

**+ GENERAL ARRANGEMENT DRAWING**

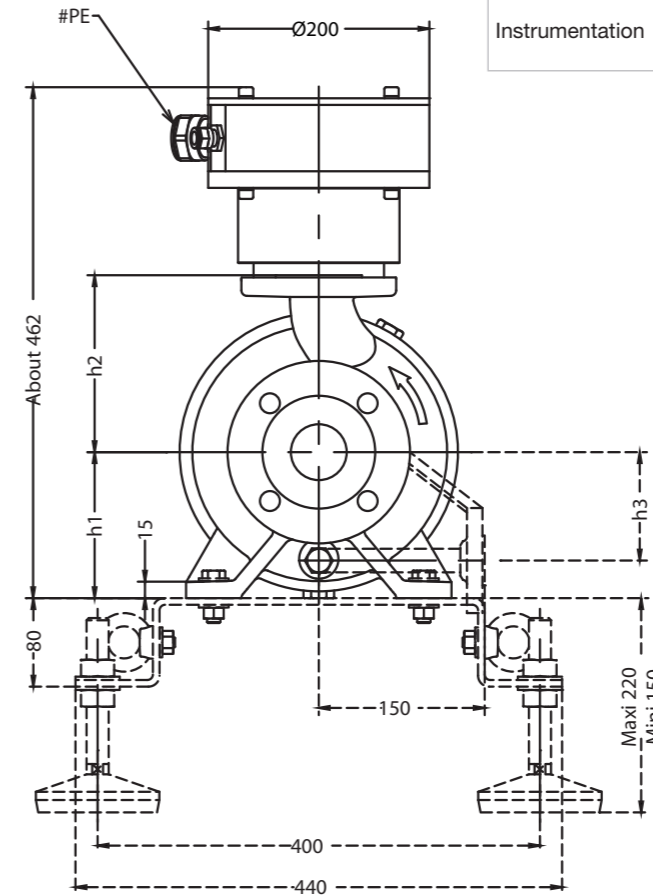
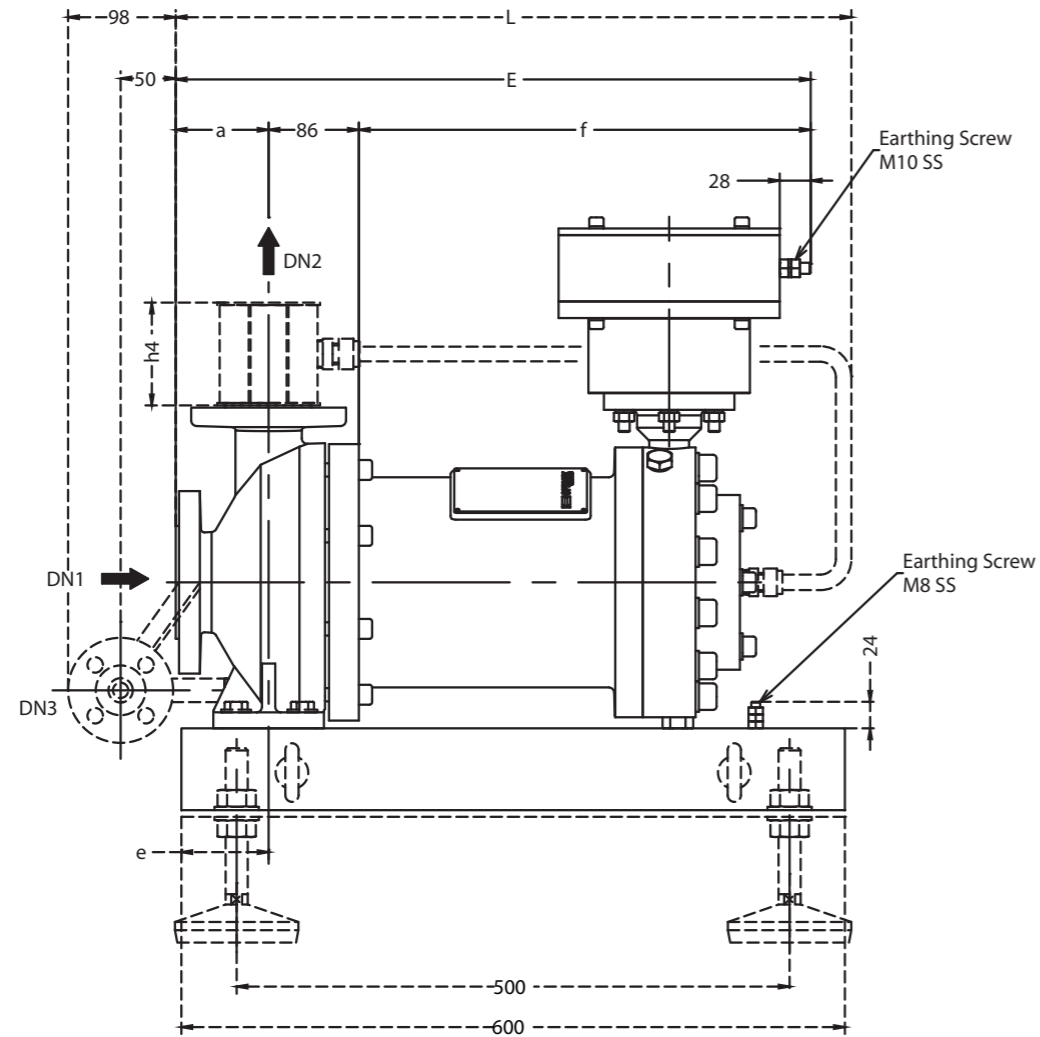

#PE: STUFFING BOX		
	Non Armoured Cable 1F	Armoured Cable 4F
Motor Supply	ADE 1F n°8 Øcable: 18 to 27.5mm	ADE 4F n°8 Øcable int.: 13.5 to 21mm Øcable ext.: 18 to 27.5mm
Instrumentation	ADE 1F n°5 Øcable: 7 to 12mm	ADE 4F n°6 Øcable int.: 7 to 12mm Øcable ext.: 10 to 16mm

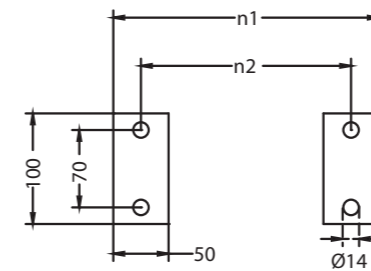
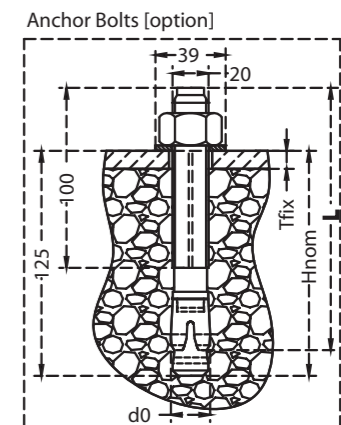
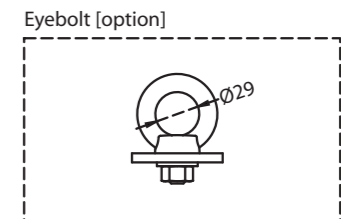
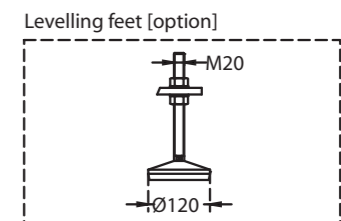
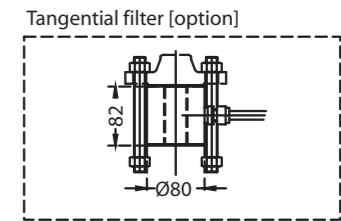

	SUCTION DN1	DISCHARGE DN2	DRAIN DN3	Motor P4																Motor P7				Motor PID			
				a mm	h1 mm	h2 mm	h3 mm	h4 mm	n1 mm	n2 mm	e mm	f mm	E mm	L mm	W kg	f mm	E mm	L mm	W kg	f mm	E mm	L mm	W kg				
CNS32/160	DN50 PN16 RF	DN32 PN16 RF	DN15 PN16 RF or 1/2"GAZ Nut	80	132	160	98	82	240	190	85	350	516	550	115	410	576	610	130	470	636	670	145				
CNS32/200	DN50 PN16 RF	DN32 PN16 RF		80	160	180	120	82	240	190	85	350	516	550	120	410	576	610	135	470	636	670	150				
CNS40/160	DN65 PN16 RF	DN40 PN16 RF		80	132	160	106	112	240	190	85	350	516	550	115	410	576	610	130	470	636	670	145				
CNS40/200	DN65 PN16 RF	DN40 PN16 RF		100	160	180	122	112	265	212	65	350	536	570	120	410	596	630	135	470	656	690	150				
CNS50/160	DN80 PN16 RF	DN50 PN16 RF		100	160	180	117	151	265	212	65	350	536	570	120	410	596	630	135	470	656	690	150				

Based on NF EN 1092-1

**+ INSTRUMENTATIONS**

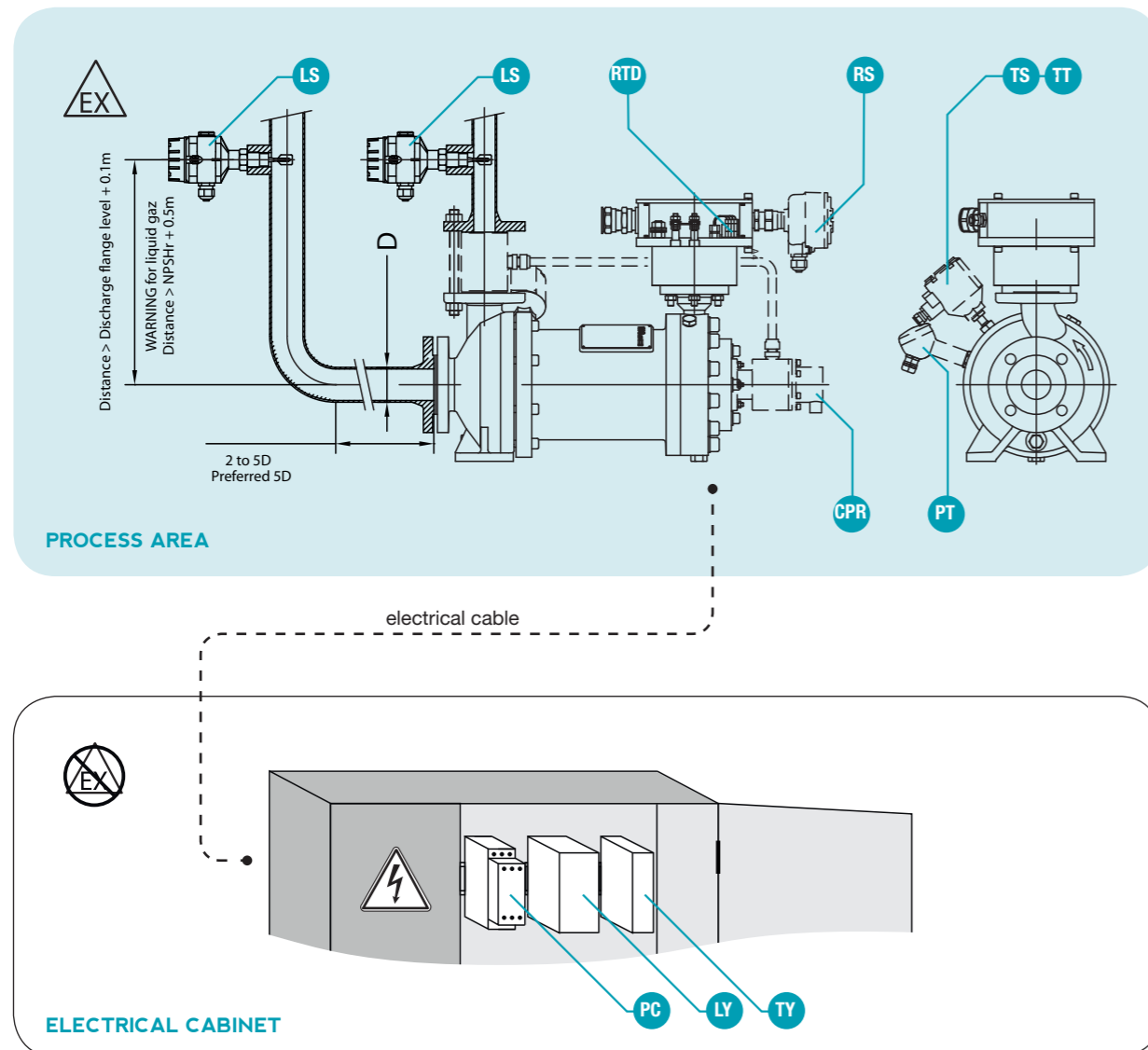

Rep	Description	Use to
TS	Liquid temp. element	Control heating of liquid in motor chamber
TT	Liquid temp. sensor with transmitter	Control heating of liquid in motor chamber
RTD	Windings temp.	Control heating of motor
TY	Relay for PTC	-
LS	Liquid level sensor	Control liquid detection
LY	Amplifier NAMUR for LS	-
PC	Power amplifier controller	Control current consumption
PT	Pressure transmitter	Control failure of second containment
RS	Rotation dir. Sensor	Control rotation way of motor
CPR	Rotor pos. controller	Prevent damages of balancing system

**LIQUID TEMPERATURE SENSOR (TS)**

By a PT100 sensor installed on the hottest point of the liquid in the pump. This device is used to measure liquid temperature in order to prevent heating in the stator chamber. PT100 sensor is mounted in a thermowell. This thermowell allows the sensor change without draining the pump. Temperature sensor is proposed with different types of ATEX protection according to your needs.

- "ia" : intrinsic safety
- "d" : explosion proof safety
- with or without transmitter 4-20 mA (SIL2 in option)

**LIQUID LEVEL SENSOR (LS)**

By a tuning fork sensor installed on different location next to the pump.

- Installed on process pipe at suction: recommend by OPTIMEX to avoid any NPSH problem
- Installed on process pipe at discharge above the top of the pump
- Installed on the pump on counter-flange

Liquid level sensor is proposed with different types of ATEX protection according to your needs.

- "ia" : intrinsic safety
- "d" : explosion proof safety

**WINDINGS TEMPERATURE SENSOR (RTD)**

Motor protection can be ensured by different types of thermistors. Thermistors are installed to prevent windings overheat. These devices are installed inside the motor. Relay (TY) and amplifier (LY) installed in the main monitoring control can be proposed upon request.

Sensor	Terminal box position	Signal	ATEX protection
PTC triple	#1	switch	included in motopump certificate
	#2		"d"
PT100	#1	resistance	included in motopump certificate
	#2	4-20 mA	"d"

#1: in the power supply terminal box  
#2: in a separate instrumentation terminal box

**PRESSURE TRANSMITTER (PT)**

In order to detect a pressure variation in the stator chamber that would indicate a leakage through the first containment. A pressure transmitter mounted on motor frame can be proposed as option.

**ROTOR POSITION CONTROL (CPR)**

This device is a magnetostrictive sensor mounted on the back of the motor. It allows to measure rotor position during pump working. It is built in "d" protection to be used in explosive area according to directive 2014/34/EU.

**ROTATING SENSOR (RS)**

Proposed as option, the rotation direction sensor is a local visual indicator without any output signal, installed on motors' terminal box. It allows the user to check whether the motopump group rotates in the right direction. This verification is essential for each start up. Use is very simple and it is built in "d" protection to be used in explosive area according to directive 2014/34/EU.

**POWER CONTROLLER (PC)**

Power controller is installed in the MCC. It is used to monitor the absorbed power by current measurement. It provides warnings when abnormal conditions are detected. This sensor can replace a VFD use.

**+ SPARE PARTS**

**PHILOSOPHY**

Due to the high reliability of canned motor pump technology, only a minimum quantity of spare parts need to be stocked. Other are available in our stock and can be supply with short lead time. For critical items, we recommend to have a spare pump in your warehouse for quick replacement.

Parts	#	Number of identical pumps (n)							
		1 to 3	4 to 6	> 6	1 to 3	4 to 6	7 to 9	> 9	
		Recommended number of spare parts							
		Start-up			Normal maintenance				
Set of gaskets	#600.01 #610.06 #600.04 #M610.02	1	2	n/3	1	2	n/3	n/3	
Set of motor bearings	#PAL1 #PAL2	1	1	2	1	2	n/3	n/3	
Set of wear rings	#103	1	1	1	1	1	2	n/3	
Thrust balancing system	#440	-	-	-	1	2	n/3	n/3	
Impeller	#230	-	-	-	1	1	2	n/3	
Stator	#MOT	-	-	-	1	1	2	n/3	
Terminal box	#BAB	-	-	-	1	1	2	n/3	
Rotor	#231 #ROT	-	-	-	1	1	2	n/3	

**LOCATION ON PUMP**

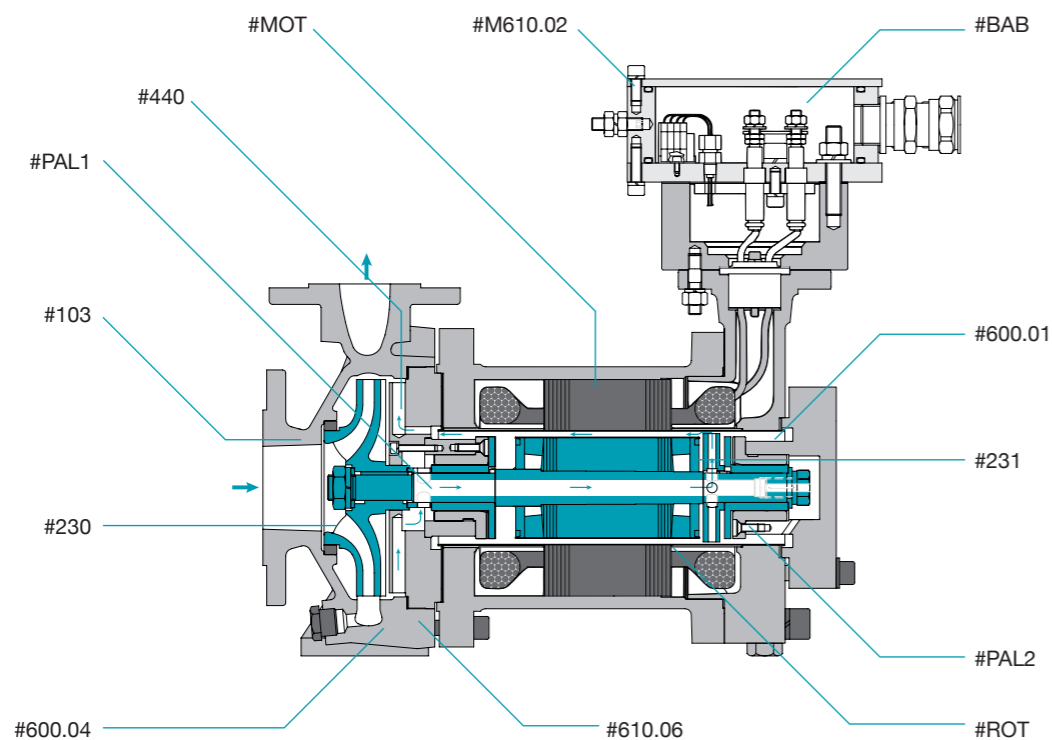

**#PAL**

Complete motor Bearing - Graphite construction

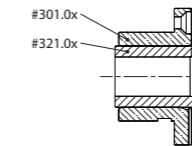

#	Parts	Material
#301.0x	Thrust bearing	Graphite
#321.0x	Shaft sleeve	1.4404 (316L)

x=1 Front side  
x=2 Rear side

**#PAL**

Complete motor Bearing - SIC30 construction

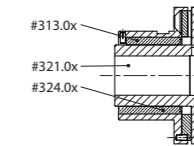

#	Parts	Material
#313.0x	Thrust bearing	1.4404 (316L) + SIC30
#321.0x	Shaft sleeve	1.4404 (316L)
#324.0x	Stop Insert	Graphite

x=1 Front side  
x=2 Rear side

**#BAB**

Complete terminal box

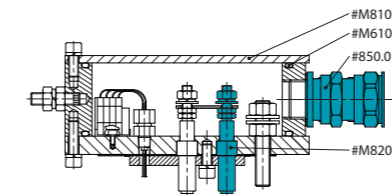

#	Parts
#M610.02	O-ring
#M810	Terminal box cover
#M820	Terminal
#M850.01	Stuffing box

**#ROT**

Complete Rotor

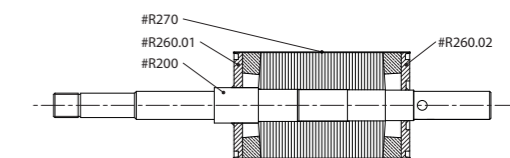

#	Parts
#R200	Shaft
#R260.01	Front rotor liner disk
#R260.02	Rear rotor liner disk
#R270	Rotor liner

**#MOT**

Complete stator

#	Parts
#M100	Motor Frame
#M110	Windings
#M111	Terminal box support
#M130	Stator liner
#M140.01	Front stator disk
#M140.02	Rear stator disk
#M884	Leak proof feedthrough

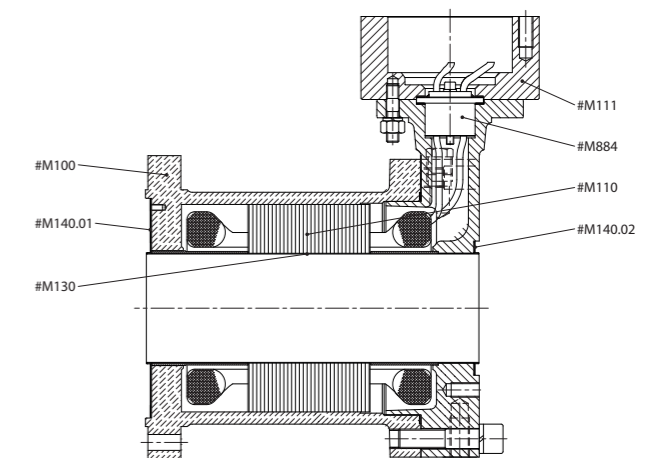





**OPTIMEX**  
CANNED MOTOR PUMPS

269, rue de Montepy  
69210 Fleurieux sur l'Arbresle  
France

Tél : +33 (0)4 72 52 95 74  
contact@optimex-pumps.com

[www.optimex-pumps.com](http://www.optimex-pumps.com)